



National Fire Equipment Ltd.

CONTINUOUS FLOW HOSE REEL CABINETS



CR-1300 & CS-1300 SERIES REEL CABINETS

Designed for swing type continuous flow hose reels and constructed similar to NFE Fire Hose Cabinets. 14 Gauge (2mm) fronts with full-length semi-concealed piano hinge and flush stainless steel door latch. The cabinet door can be removed for either left or right swing. The tubs are constructed of 18 Gauge (1.19mm) metal c/w a reinforcement plate to support hose reels. All edges of the entire cabinet are ground and rounded for safety.

WARNING: Standard baked enamel cabinets are not designed for outdoor applications. Depending on environment use epoxy coatings, galvanized, stainless steel or fiberglass materials. Contact our customers service representatives for assistance.

Specifications:

Surface mounted reel cabinets shall be NFE CS-_____, ___"x___"x___" with 18 gauge (1.19mm) baked grey enamel corrosion protected steel tubs. The cabinet tub shall be reinforced to support the hose reel. 14 Gauge (2mm) grey baked enamel corrosion protected steel door & frame with hollow channel reinforcement. The frame section can be site adjusted for left or right door swing. Complete with full-length semi-concealed piano hinges, Model SMSS flush stainless steel door catch, and full panel of 3/16" (5mm) Glass.

Specifications:

Recessed cabinets shall be CR_____, ___"x___"x___" with 18 gauge (1.19mm) baked white enamel corrosion protected steel tubs. The cabinet tub shall be reinforced to support the hose reel. 14 Gauge (2mm) grey baked enamel corrosion protected steel door & frame with hollow channel reinforcement. Front section to have 2" (51mm) adjustment to wall surface and complete with 1/2" (13mm) turn back frame. Complete with full-length semi-concealed piano hinges, Model SMSS flush stainless steel door catch, and full panel of 3/16" (5mm) Glass. Stainless steel Fronts to have fully concealed "Soss" hinges.

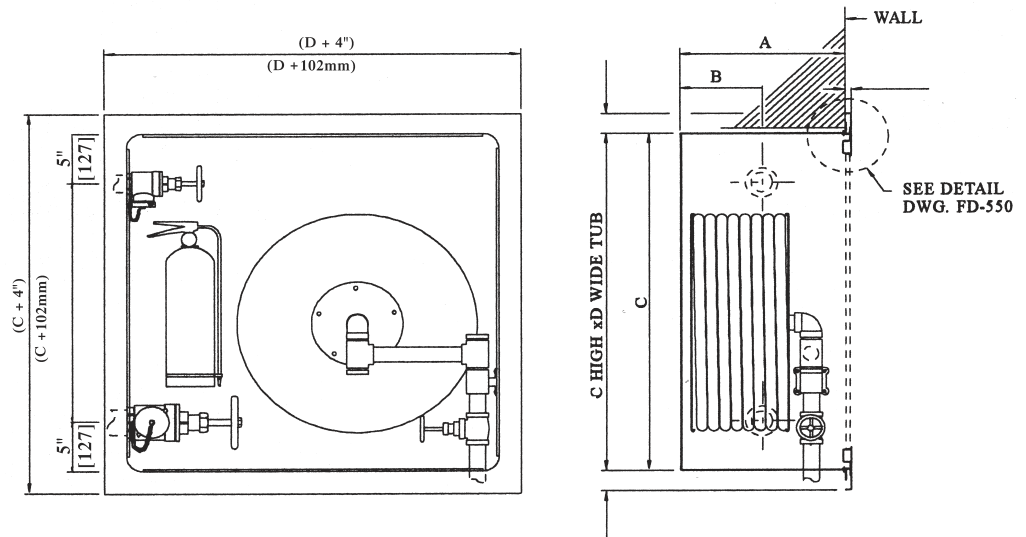

MODEL	MOUNTING TYPE	DIMENSIONS				FIRE EXTINGUISHER MAXIMUM	VALVE
		A	B	C	D		
CR-1310	RECESSED	12" (300mm)	N/A	30" (762mm)	30" (762mm)	5LB DRY CHEM	—
CS-1310	SURFACE	12" (300mm)	N/A	30" (762mm)	30" (762mm)	5LB DRY CHEM	—
CR-1320	RECESSED	12" (300mm)	N/A	30" (762mm)	34" (864mm)	20LB DRY CHEM	—
CS-1320	SURFACE	12" (300mm)	N/A	30" (762mm)	34" (864mm)	20LB DRY CHEM	—
CR-1330	RECESSED	12" (300mm)	6" (150mm)	34" (864mm)	30" (762mm)	5LB DRY CHEM	1 VALVE (1.5"/2.5")
CS-1330	SURFACE	12" (300mm)	6" (150mm)	34" (864mm)	30" (762mm)	5LB DRY CHEM	1 VALVE (1.5"/2.5")
CR-1340	RECESSED	12" (300mm)	6" (150mm)	34" (864mm)	34" (762mm)	5LB DRY CHEM	2 VALVES
CS-1340	SURFACE	12" (300mm)	6" (150mm)	34" (864mm)	34" (762mm)	5LB DRY CHEM	2 VALVES

