



**AURORA**<sup>®</sup>  
Pentair Water

# 420 Series Multi-Stage Split Case Pumps

- Capacities to 1800 GPM (409 m<sup>3</sup>/hr)
- Heads to 600 Feet (183 m)
- Temperatures to 275°F (135°C)

MODEL 422

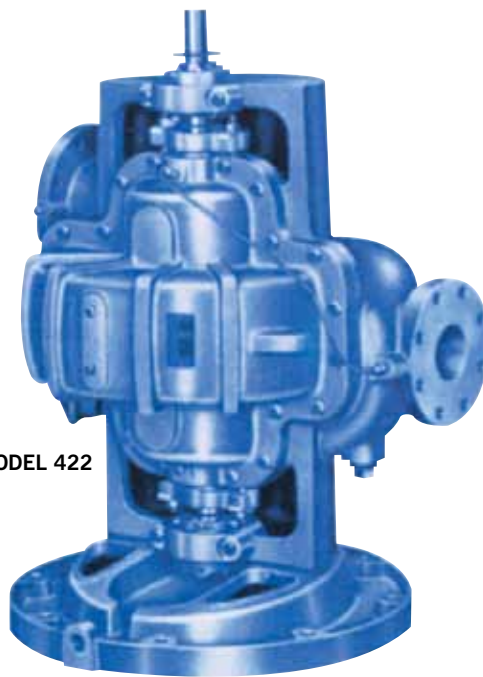

MODEL 421

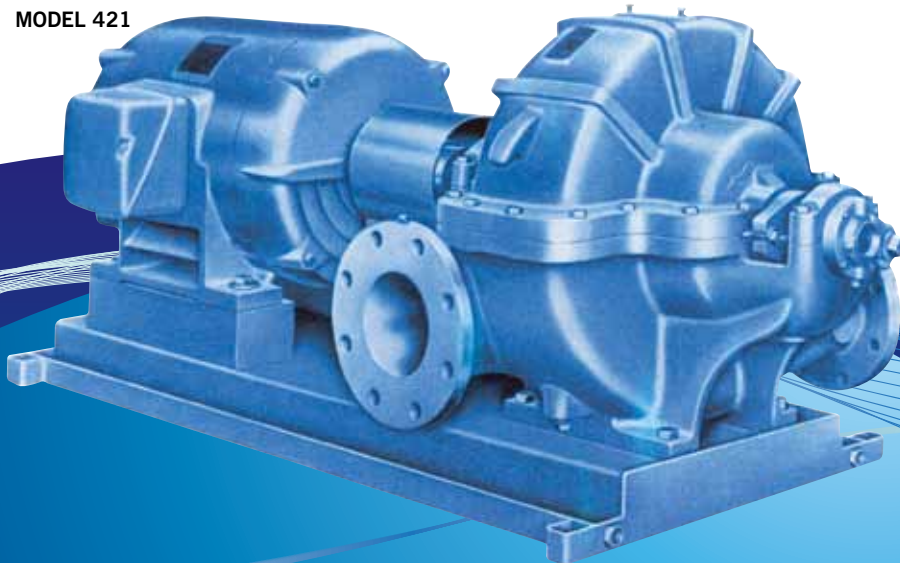

MODEL 423



# Aurora 420 Series Pumps

## Introduction

The Aurora 420 Series two-stage pumps were designed to meet today's demanding municipal, industrial, and commercial market requirements. They meet the needs of high head applications where single stage pumps will not suffice. Aurora's pumps are known for quality and reliability, and the 420 Series pumps are no exception. The attention to detail done during the design process can be seen in features such as the double row thrust bearings and line boring of the casing for the rotating element, increasing the life of the bearings and the pumps. The 422 and 423 vertical pumps have the double benefit of providing space savings as well as flood protection for the motors. Features such as these provide long life and value that Aurora's customers have come to expect, and truly differentiate them from the competition.

**Model 421** is horizontally baseplate mounted with a driver flexibly coupled to the pump. This design is recommended where floor space is readily available and where flooding of the installation is not possible.

**Model 422** is vertically mounted and uses flexible shafting between the driver and the pump. This model is frequently used on difficult applications where flooding of the installation is a possibility.

**Model 423** is vertically mounted with an elevated driver coupled directly to the pump through a flexible coupling. Model 423 is very popular for installations where available floor space is limited and where possible flooding is marginal.

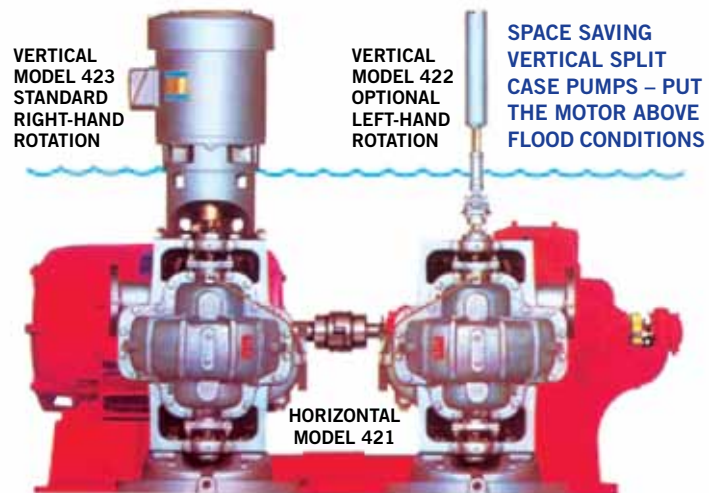

# Aurora 420 Series Pumps

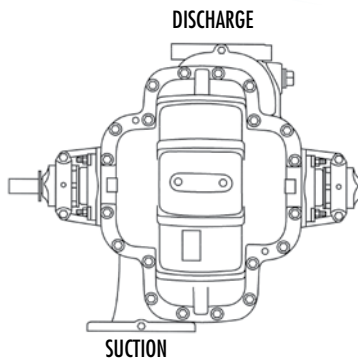

**STANDARD  
RIGHT-HAND ROTATION**

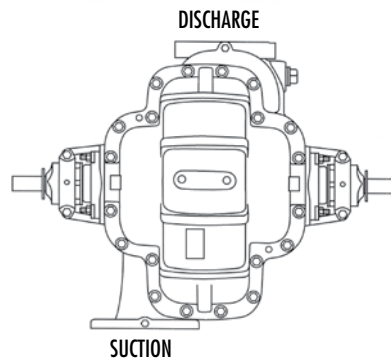

**OPTIONAL DUAL DRIVE  
RIGHT-HAND ROTATION**

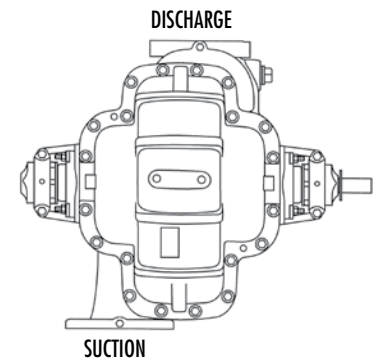

**OPTIONAL  
LEFT-HAND ROTATION**

## 420 Series Feature Selector

### Standard

- Bronze fitted pump construction
- Bronze shaft sleeves
- Dynamically balanced impellers
- Bronze case wearing rings
- Multi-volute on 2" and larger pumps
- Stainless steel impeller key
- Regreaseable ball bearings
- Single row ball bearing (inboard)
- Double row ball bearing (outboard)
- Mechanical seals...single unbalanced (Models 422 and 423)
- Interwoven, graphite/Teflon® lubricated acrylic yarn packing rings (Model 421)
- Internal bypass between casing and stuffing box (First Stage)
- 125# suct., 250# disch. ASA flanges
- 250 psi case working pressure
- Carbon steel shaft
- Stuffing box bushings
- Lifting lugs
- Hydrostatic test
- Cast integral bearing arms
- Water slingers and grease seals
- Coupling guard (Model 421)

### Optional

- All iron, all bronze or special alloy pump construction
- Hardened 440C stainless steel shaft sleeves (packing only)
- 316 stainless shaft sleeves (mechanical seals)
- Impeller wearing rings
- Oil lubricated ball bearings (Model 421 horizontal pump)
- Mechanical seals...single unbalanced (Model 421)
- Stainless steel shaft
- External bypass between casing and stuffing box
- Steel drip rim, formed steel or fabricated steel bases
- Double extended shaft (Model 421)
- Right- or left-hand rotation
- Certified performance test
- Packing with lantern ring (Model 421)
- 250# ASA suction and discharge flanges
- Water cooled bearing

# Horizontal Pump Features

## 1. Split Case Design

simplifies disassembly. The suction and discharge piping or alignment is not disturbed. Simply remove the upper casing for service or inspection. Cast lifting lugs are provided. Computer-machined major components with 360 degree registered fits assure concentric fit.

## 2. Dynamically Balanced Impellers

are keyed to shaft and secured by adjustable shaft sleeves. Opposed suction design balances out hydraulic thrust loads. Vacuum cast process and proven design provide high efficiency and performance characteristics.

## 3. Case Wearing Rings

and throttle bushings prevent wear on the pump casing and are easily and inexpensively replaced.

## 4. Bronze Shaft Sleeve

prevents shaft wear, is slip fit over the shaft, keylocked and extends the entire length of each stuffing box. Shaft sleeves and impeller are sealed by Teflon\* coated steel gaskets to eliminate corrosion of the shaft by the pumped liquid. This eliminates the need for high cost, special stainless steel or Monel® shafts.

## 5. Interchangeable Stuffing Box

for mechanical seals or packing. Packing is standard on horizontal pumps. Optional lantern ring has an internal water seal passage between the casing and stuffing box and cannot be damaged. Mechanical seals have carbon against Ni-Resist face. Long life is assured with 303 stainless steel metal parts and Buna-N elastomers. Several optional mechanical seals are available.

\*E.I. Dupont Trademark

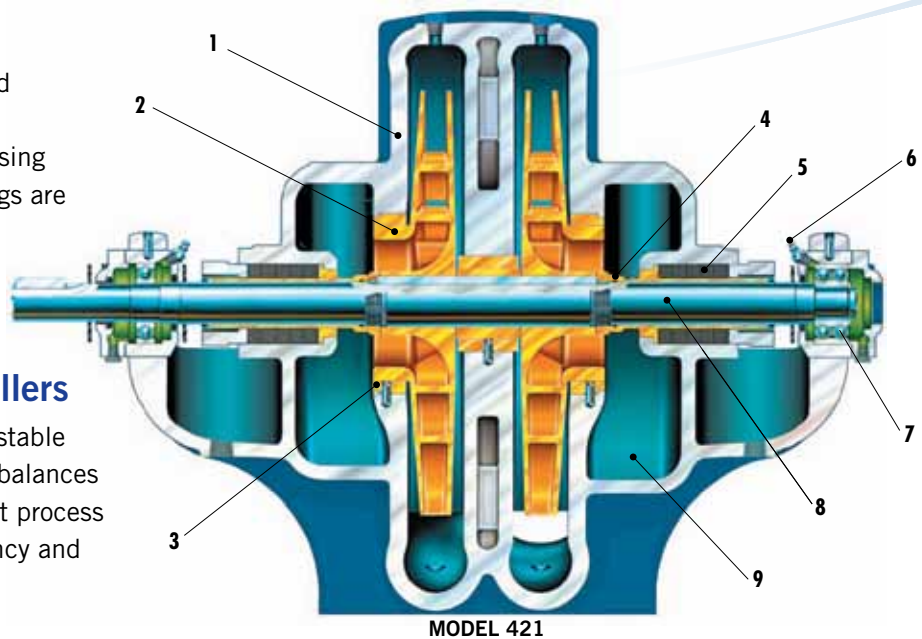

## 6. Grease Lubrication

purges old grease from bearings. Oil lubrication is optional on horizontal pumps. Lube fittings conveniently located for quick accessibility and provide positive bearing lubrication. Oil seals and nonsparking neoprene rotating slingers protect both bearings during pump operation and washdowns.

## 7. Bearings

selected for 50,000 hour minimum life at maximum load. Average bearing life 5 x minimum. Double row thrust ball bearing is standard on all models. Short bearing span holds shaft deflection to .002" at face of stuffing box at maximum load. Integral bearing arms eliminate bearing misalignment and simplify service.

## 8. Left-Hand Rotation

can be readily provided with standard parts. Tandem drive pumps require only a different shaft.

## 9. Certified Performance

with positive suction pressure or with a suction lift is available on each pump for customer approval. Pumps are all hydrostatically tested.



# Vertical Pump Features

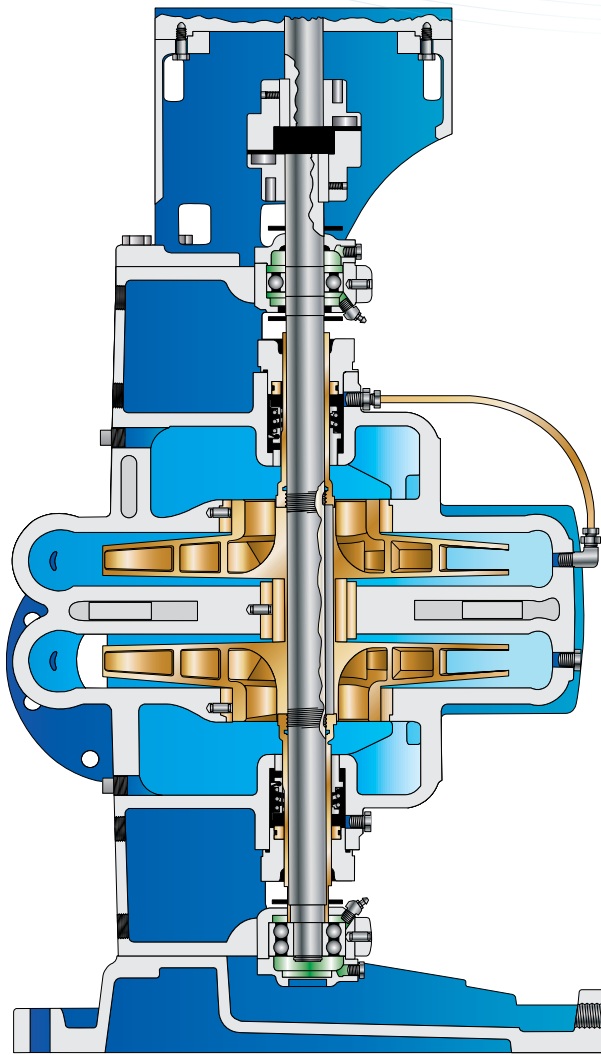

MODEL 423

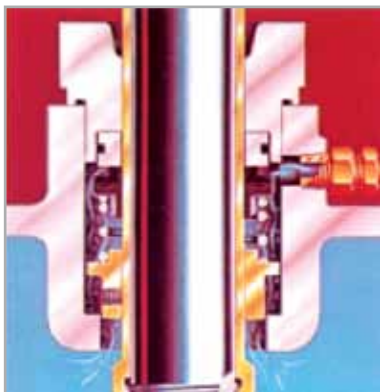

EXTERNAL UPPER SEAL FLUSH

## Benefits

Less floor space required. Typically 1/2 the floor space of a comparable Horizontal Split Case.

Inline piping arrangement allows piping in any direction.

Elevated motor protects against potential flooding if the pump station is in a low area.

## Key Features

Features described for the horizontal pumps are also found in the vertical pumps.

### 1. Coupling Alignment

with true alignment is vital to long life and proper performance. To maintain proper coupling alignment the mounting bracket is rabbet fitted to the motor.

### 2. Mechanical Seals

used with standard construction include carbon against Ni-Resist face for optimum hot water performance. Long life is also assured with 303 stainless steel metal parts and Buna-N elastomers.

### 3. Bearing Protection

in the form of grease seals and water slingers is provided to protect the bearings from contamination.

### 4. Cast Iron Drip Rim Base

assures that accurate positioning of the base is assured by the mounting base. A drip rim is incorporated in the base design to control condensation and leakage.

### 5. Standard External Upper Seal Flush

eliminates air entrapment on the upper mechanical seal and lengthens seal.

# 420 Series Range Charts

## 3600 RPM

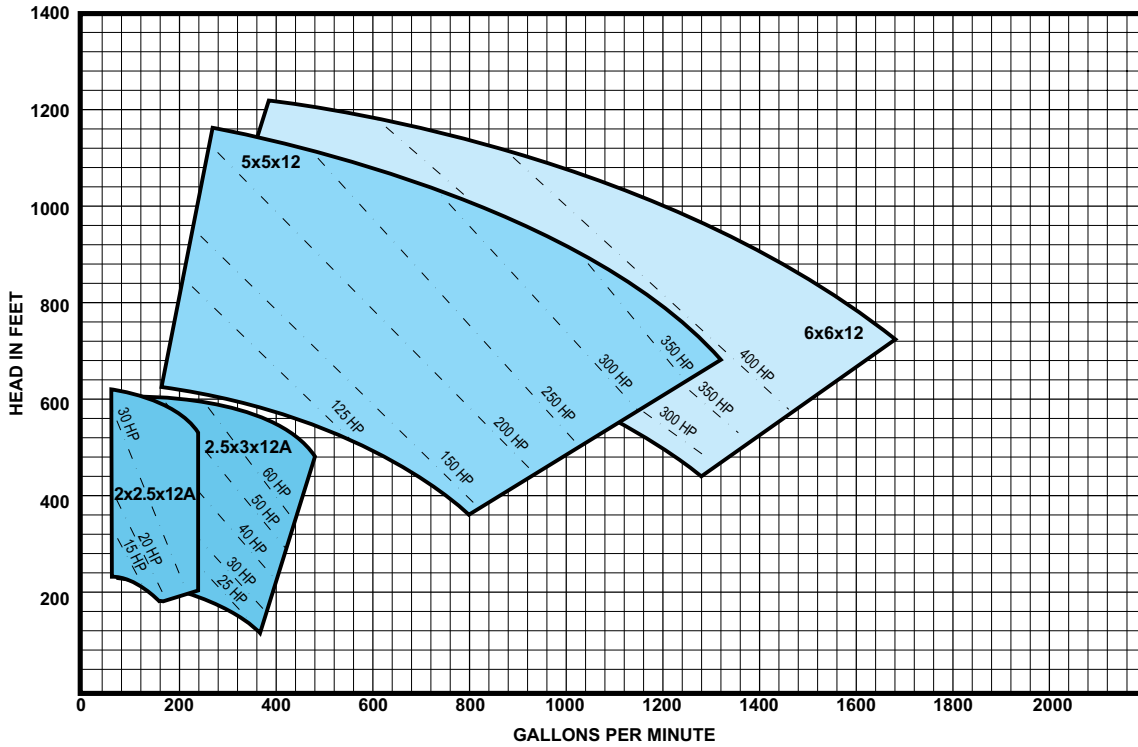

Individual performance curves must be used for final selection. For selections not shown on this chart please refer to the factory.

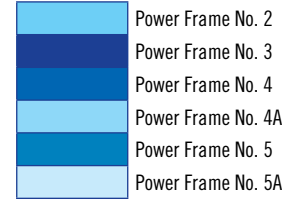

## 1800 RPM

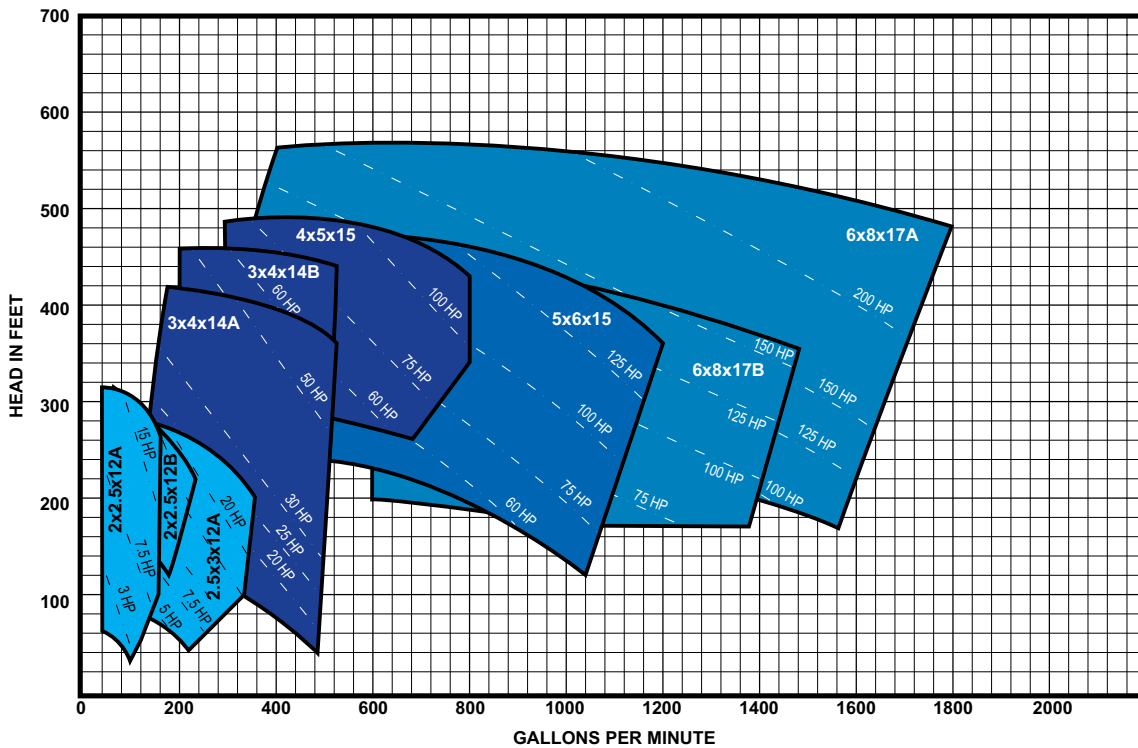

# 420 Series Range Charts

## 3000 RPM

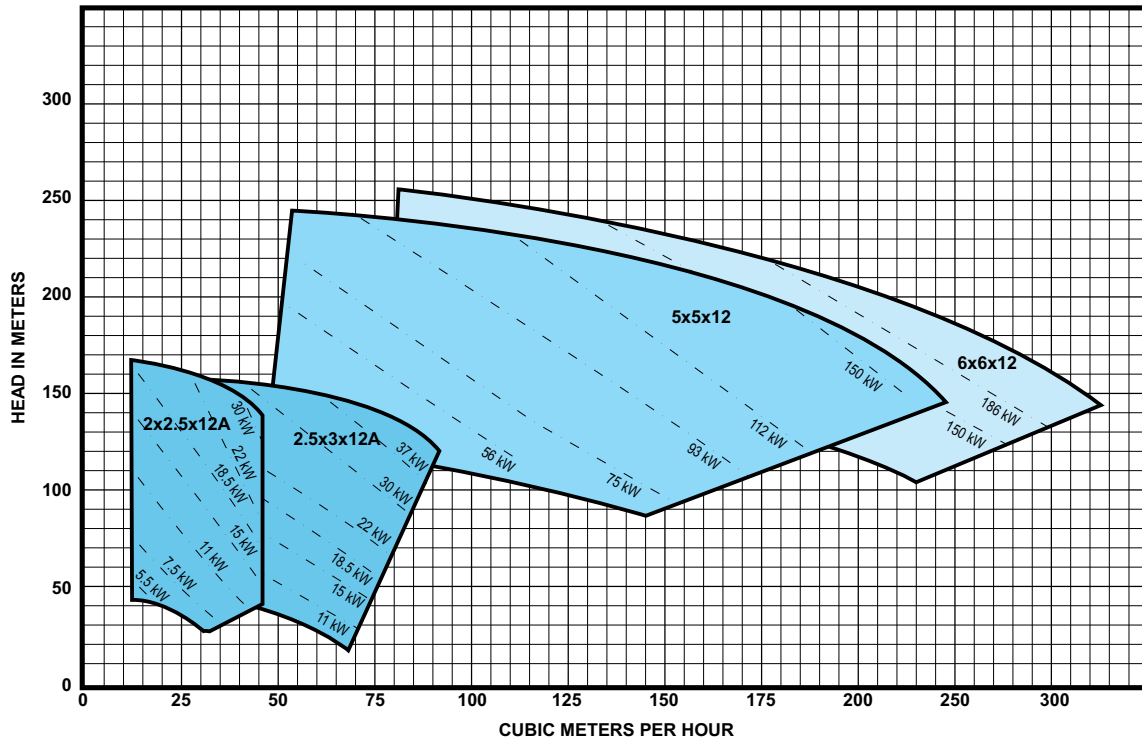

## 1500 RPM

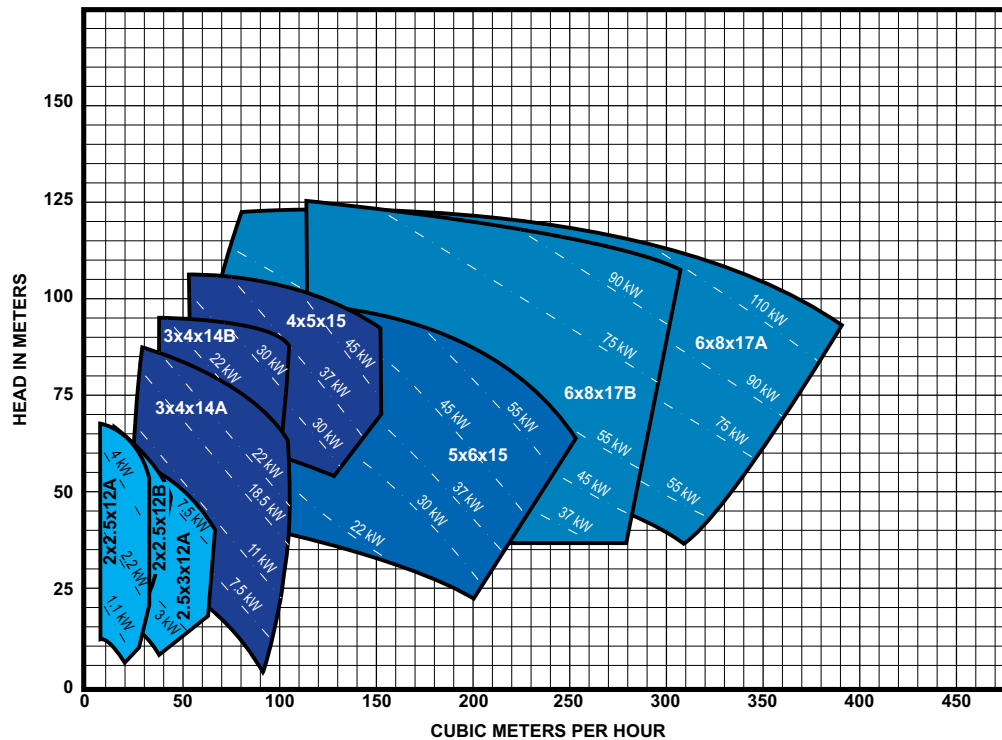

# Pump Dimensions

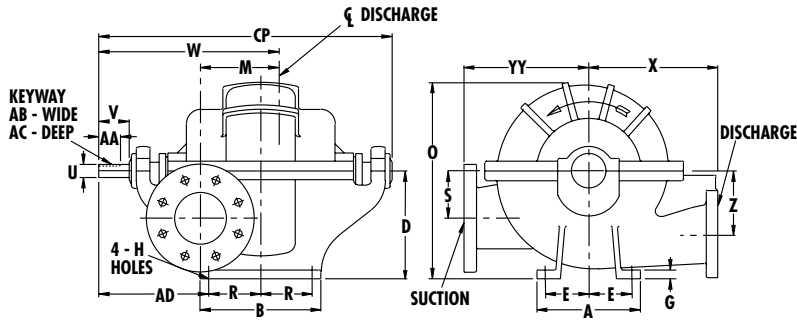

## Model 421 – Right-Hand Rotation

Model	Pump Size			Power Series																					
	Disch.	Suction	Case Bore		A	B	D	E	G	H	M	O	R	S	U	V	W	X	Z	AA	AB	AC	AD	CP	YY
2x2.5x12A/ 2x2.5x12B	2	2-1/2	12	2	8 (203)	10 (254)	9 (229)	3-1/2 (89)	3/4 (19)	5/8 (16)	4-3/4 (121)	19 (483)	4 (102)	4 (102)	1-1/8 (29)	2-3/4 (70)	15-3/4 (400)	10 (254)	5-1/2 (140)	2 (51)	1/4 (6)	1/8 (3)	10-1/2 (268)	26-1/4 (667)	10-1/4 (260)
2.5x3x12A	2-1/2	3	12	2	8 (203)	10 (254)	9 (229)	3-1/2 (89)	3/4 (19)	5/8 (16)	5-3/8 (137)	19 (483)	4 (102)	4 (102)	1-1/8 (29)	2-3/4 (70)	15-7/8 (403)	11 (279)	5-1/2 (140)	2 (51)	1/4 (6)	1/8 (3)	10-1/2 (268)	26-1/4 (667)	11 (279)
3x4x14A/ 3x4x14B	3	4	14	3	10 (254)	12 (305)	10 (254)	4-1/4 (108)	7/8 (22)	3/4 (19)	6-3/4 (171)	21 (533)	5 (127)	4-1/2 (114)	1-3/8 (35)	3 (76)	18-3/4 (476)	12 (305)	6 (152)	2 (51)	3/8 (10)	3/16 (5)	12 (305)	31 (787)	12-3/8 (314)
4x5x15	4	5	15	3	10 (254)	12 (305)	11 (279)	4-1/4 (108)	7/8 (22)	3/4 (19)	7-1/8 (181)	23 (584)	5 (127)	5 (127)	1-3/8 (35)	3 (76)	18-7/8 (479)	13 (330)	6-1/2 (165)	2 (51)	3/8 (10)	3/16 (5)	12 (305)	31 (787)	13-1/2 (343)
5x5x12	5	5	12	4A	15 (381)	16 (305)	14 (356)	6-1/2 (165)	1 (25)	7/8 (22)	6-5/8 (168)	24-1/4 (616)	7 (178)	7 (178)	1-1/2 (38)	3-5/8 (92)	20-7/8 (530)	13 (330)	7 (178)	2-1/2 (64)	3/8 (10)	3/16 (5)	12-1/2 (318)	35-3/8 (899)	13 (330)
5x6x15	5	6	15	4	12 (305)	14 (356)	12-1/2 (318)	5 (127)	1 (25)	7/8 (22)	9-1/8 (232)	24-1/2 (622)	6 (152)	5-1/2 (140)	1-1/2 (38)	3-1/2 (89)	21-1/8 (537)	15 (381)	7-1/2 (191)	2 (51)	3/8 (10)	3/16 (5)	13 (330)	34-1/2 (876)	15-7/16 (392)
6x6x12	6	6	12	5A	16 (406)	19 (483)	15 (381)	7 (178)	1 (25)	7/8 (22)	7-1/2 (191)	26-1/4 (667)	8-1/2 (216)	8 (203)	1-3/4 (44)	4 (102)	22-7/8 (581)	14 (356)	8 (203)	2-3/4 (70)	3/8 (10)	3/16 (5)	12-3/4 (324)	38-1/2 (978)	14 (356)
6x8x17A/ 6x8x17B	6	8	17	5	12 (305)	14 (356)	14-3/4 (375)	5 (127)	1 (25)	7/8 (22)	11 (279)	28-1/4 (718)	6 (152)	7 (178)	1-3/4 (44)	4 (102)	24-1/2 (622)	16 (406)	9 (229)	2-7/8 (73)	3/8 (10)	3/16 (5)	15 (381)	38 (965)	16-1/2 (419)
6x8x16/ 6x8x16B	6	8	16/ 16B	5	12 (305)	14 (356)	16.50 (419)	5 (127)	1 (25)	.88 (22)	10.50 (267)	33.50 (851)	6 (152)	8.25 (210)	1.75 (44)	4 (102)	23.63 (600)	19 (483)	7.75 (197)	2.88 (73)	3/8 (10)	3/16 (5)	15 (381)	37.88 (962)	17 (432)

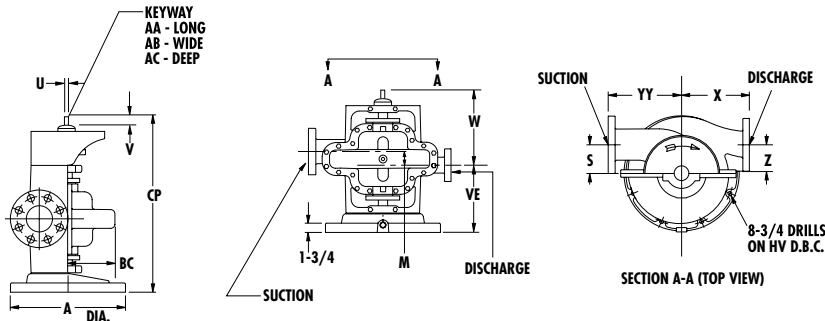

## Model 422 – Right-Hand Rotation

### NOTES – APPLY TO ALL MODELS

- All dimensions are in inches (mm).
- Dimensions may vary  $\pm 3/8"$  (10).
- Not for construction purposes unless certified.
- Suction & discharge flanges – American Standard flat face.

### APPLY TO MODEL 421 ONLY

- \*5x5x12 and 6x6x12 Standard 150# Suction Flanges & 300# Discharge Flanges.
- †5x5x12 and 6x6x12 Opt. 300# Flanges.

Model	Pump Size			Power Series																
	Disch.	Suction	Case Bore		A	M	S	U	V	W	Z	AA	AB	AC	BC	CP	HV	VE	X	YY
2x2.5x12A/ 2x2.5x12B	2	2-1/2	12	2	18 (457)	4-3/4 (121)	4 (102)	1-1/8 (29)	2-3/4 (70)	15-3/4 (400)	5-1/2 (140)	2 (51)	1/4 (6)	1/8 (3)	10 (254)	28-5/8 (651)	16-1/4 (413)	12-7/8 (327)	10 (254)	10-1/4 (260)
2.5x3x12A	2-1/2	3	12	2	18 (457)	5-3/8 (137)	4 (102)	1-1/8 (29)	2-3/4 (70)	15-7/8 (403)	5-1/2 (140)	2 (51)	1/4 (6)	1/8 (3)	10 (254)	28-5/8 (651)	16-1/4 (413)	12-3/4 (324)	11 (279)	11 (279)
3x4x14A/ 3x4x14B	3	4	14	3	22 (559)	6-3/4 (171)	4-1/2 (114)	1-3/8 (35)	3 (76)	18-3/4 (476)	6 (152)	2 (51)	3/8 (10)	3/16 (5)	11 (279)	33-1/2 (851)	20 (508)	14-3/4 (375)	12 (305)	12-3/8 (314)

STD. 125# SUCTION FLANGES & 250# DISCHARGE FLANGES*	OPT. 250# FLANGES*
-----------------------------------------------------------------	-----------------------



# Pump Dimensions

## Model 423 – Right-Hand Rotation

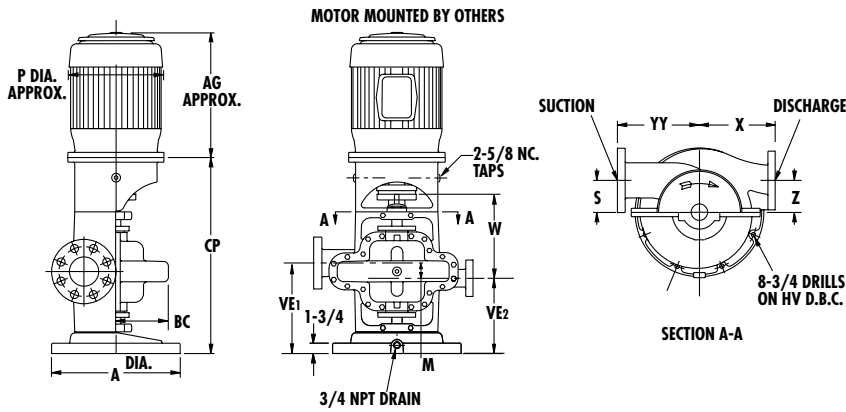

Model	Pump Size			Power Series	CP											
	Disch.	Suction	Case Bore		A	M	S	W	Z	BC	143HP-256HP	284HP-404HP	HV	VE	X	YY
2x2.5x12A/ 2x2.5x12B	2	2-1/2	12	2	18 (457)	4-3/4 (121)	4 (102)	15-3/4 (400)	5-1/2 (140)	10 (254)	32-1/8 (816)	34 (864)	16-1/4 (413)	12-7/8 (327)	10 (254)	10-1/4 (260)
2.5x3x12A	2-1/2	3	12	2	18 (457)	5-3/8 (137)	4 (102)	15-7/8 (403)	5-1/2 (140)	10 (254)	32-1/8 (816)	34 (864)	16-1/4 (413)	12-3/4 (324)	11 (279)	11 (279)
3x4x14A 3x4x14B	3	4	14	3	22 (559)	6-3/4 (171)	4-1/2 (114)	18-3/4 (476)	6 (152)	11 (279)	37-3/8 (949)	39-3/4 (1010)	20 (508)	14-3/4 (375)	12 (305)	12-3/8 (314)

Frame	143 HP	145 HP	182 HP	184 HP	213 HP	215 HP	254 HP	256 HP	284 HP	286 HP	324 HP	326 HP	364 HP	365 HP	404 HP
P	8	8	10	10	11	11	13	13	16	16	18	18	20	20	22
AG	11	12	13	14	16	18	20	22	23	24	25	27	32	32	35

# Engineering Specifications

## Models 421, 422 and 423 Horizontal Split Case

Furnish and install as shown on the plans...

Right-hand (Left-hand) Aurora Model (Horizontal-421) (Vertical-422 Open Shaft) (Vertical-423 Flexible Coupled) type Split-Case, Opposed Suction, Multi-Stage centrifugal pump, Size \_\_\_\_ x \_\_\_\_ x \_\_\_\_ of bronze fitted (all bronze) (all iron) (stainless steel) construction. The pump shall be capable of delivering at design conditions a capacity of \_\_\_\_ GPM when operating against a Total Dynamic Head of \_\_\_\_ feet, with a temperature of \_\_\_\_ °F, specific gravity \_\_\_\_ . Pump shall have minimum guaranteed efficiency at design capacity of \_\_\_\_ % . Pump must also be capable of delivering a maximum of \_\_\_\_ GPM when operating against a head of \_\_\_\_ feet, and at this condition shall have a minimum efficiency of \_\_\_\_ % . Minimum shut-off head acceptable will be \_\_\_\_ feet. Pump shall operate at a maximum synchronous speed of \_\_\_\_ RPM.

A unit operating at a lesser rotative speed will be considered, but in no event will a pump operating at more than the maximum speed specified be acceptable. The pump casing halves shall be of the inline piping design and will be constructed of Class 30 Cast Iron having a minimum tensile strength of 30,000 psi and shall be of sufficient thickness to withstand stresses and strains at full operating pressures.

Casings shall be subject to a hydrostatic pressure test at 150% of the specified duty point. Bearing housing supports, suction and discharge flanges shall be integrally cast with the lower half of the casing. Removal of the upper half of the casing must allow the rotating element to be removed without disconnecting the suction and discharge piping. The upper casing is to be dowel aligned to the lower casing.

Pump sizes 2" and larger are to be of the multi-volute design. Drain openings must be provided in the bearing arms for removal of lubricating liquid. Impellers shall be of the enclosed, opposed suction type and shall be of vacuum cast bronze ( \_\_\_\_ ). Impellers shall be dynamically balanced and securely fastened to the shaft by key and screw locked shaft sleeves. The vanes shall be designed to reduce noise. The pump shaft shall be made of high grade SAE 1045 Steel or equal, accurately machined to give a true running rotating element. The minimum dia. acceptable will be \_\_\_\_ ". The shaft shall be protected from wear by bronze ( \_\_\_\_ ) sleeves which are key locked and threaded so that the sleeves tighten with the rotation of the shaft. Teflon® coated steel gaskets must be provided between the impeller hub and the shaft sleeves to prevent pumped liquid from corroding the shaft.

Pump shall be equipped with easily renewable bronze ( \_\_\_\_ ) casing rings (impeller wearing rings) so designed that hydraulic pressure will seat them against a shoulder in the pump case around the full periphery of the wearing ring. The wear rings will be locked in place by dowelling to prevent rotation. The rotating element shall be mounted in heavy duty grease lubricated ball bearings and shall be equipped with water slingers on side next to pump glands.

Bearing housings shall be so designed to flush lubricant through and provide continuous cleaning of bearing surfaces and maximum protection against overheating. The bearing housings are to be of C.I. and shall be furnished with a set of regreaseable (optional oil lubricated on Model 421) bearings for both radial and thrust loads. The bearings shall have an average life of 250,000 hours and shall be mounted in machined, moisture and dust-proof housings. The housings are to have register fits and then be bolted to the pump casing to ensure permanent alignment.

## Model 421

Stuffing boxes shall be placed on both sides of the pump centerline to seal the pump shaft. All packed pumps having a suction lift have a 1st stage lantern ring connected to the pressure side of the pump by a cored passage in the parting flange of the pump. The stuffing boxes shall be equipped with heavy, cast, split glands with extra length for easy removal for packing inspection and maintenance. Pump and motor shall be mounted on a common heavy base plate of (steel drip rim) (formed steel) (structural steel). Pump and motor must be checked for alignment after the pump base has been installed and grouted in place, in accordance with the standards of the Hydraulic Institute. There shall be no strain transmitted to the pumps.

## Models 422 and 423

Mechanical seal boxes shall be placed on both sides of the pump centerline to seal the pump shaft. Each pump is to be furnished with mech. seals with all metal parts to be 303 stainless steel with Buna-N elastomers, Ni-Resist seat, and carbon washer. A bypass line must be provided for the upper seal between the seal faces and the discharge flange to assure adequate venting of the seal chamber and to provide lubrication. All pumps shall be provided with a cored passage in the parting flange of the pump to provide additional circ. to 1st stage seal. The mech. seal boxes shall be equipped with heavy, cast, one piece, O-ring sealed glands. The pump shall be supported by a cast iron drip rim base.

## Model 422

Vertical open shaft pumps are to be driven through flexible shafting with \_\_\_\_ dia. tubing and intermediate bearings. Shafting must be of sufficient size to transmit required H.P. and must be provided with a slip spline which will permit removal of the pump rotating assembly without removing any section of intermediate shafting, bearings, suction or discharge piping.

## Model 423

Vertical flexible coupled pumps shall be furnished with a cast iron motor bracket which is to be bolted to the vertical casing. The motor bracket must be machined with a register fit to ensure proper alignment of motor and pump shaft.

## Models 421 and 423

The pumps shall be flexible coupled to a standard (horizontal) (vertical) NEMA \_\_\_\_ HP \_\_\_\_ phase \_\_\_\_ Hertz \_\_\_\_ volts \_\_\_\_ RPM (drip proof) (tot. encl.) (hazardous location) motor.

**NOTE:** Aurora Pump reserves the right to make revisions to its products and their specifications, and to this brochure and related information, without notice.

---



800 Airport Road • North Aurora, Illinois 60542 • Phone: 888-987-8680  
3601 Fairbanks Avenue • Kansas City, Kansas 66106 • Phone: 888-416-9510  
1101 Myers Parkway • Ashland, Ohio 44805 • Phone: 888-416-9513  
8263 Florida Boulevard • Denham Springs, Louisiana 70726 • Phone: 800-219-9183

[www.aurorapump.com](http://www.aurorapump.com)

A-02-1018 10/11 © 2011 Pentair Pump Group, Inc.