

Series 790 Constant Pressure Booster Systems • with stackable pumps

- Capacities to 1200 G.P.M. (272.5 M³/HR)
- Pressures to 346 PSI (244 M)
- Potable Water Application



Constant Pressure Pumping Introduction

CP Boss, Aurora Pump's Packaged Constant Pressure Booster Systems are designed to meet the ever increasing demand of variable flows in high-rise, commercial, municipal and industrial buildings. These PLC based systems are available in vertical configurations. Easy to select and install, pre-engineered duplex and triplex units are available for quick delivery. Each system is performance tested for trouble free operation and ease of installation and start-up.

Feature Selector

STANDARD

- UL Labeled Pressure Sensing Control Panel
- PLC Pump Sequence Controller
- Duplex or Triplex
- Vertical Configurations
- Vertical Stackable Pumps
- High Efficiency Motors
- Steel Manifolds
- Complete Factory Test
- Pilot Operated Pressure Regulating Valves
- Maximum Pressure up to 175 PSI, Maximum Flows up to 1200 GPM
- Single Source Responsibility

OPTIONAL

- ASME rated Steel Bladder Tank
- Galvanized, Copper or Stainless Steel Headers
- Special Control Panels
- Current Sensing or Flow Sensing
- Simplex, Quadruplex Designs
- Specially Engineered Booster Systems for Higher Flows & Pressures



Packaged Constant Pressure Booster Systems described in this bulletin are used in offices and high rise buildings.

Pump Features

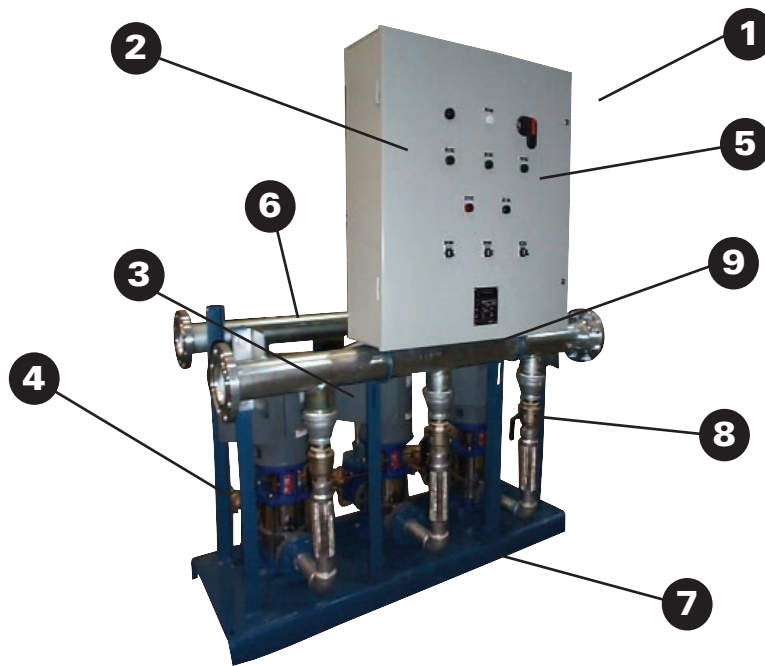

FEATURES

1. COMPLETELY ASSEMBLED and prewired for easy installation.
2. PRESSURE SENSING CONTROL PANEL: The Programmable Controller incorporated into the UL listed NEMA 1 Control Panel readily allows for the addition of optional control functions and alarm features.
3. SYSTEMS feature Aurora Pump 390 Series vertical multi-stage in-line pumps in stainless steel construction.
 - HIGH TEMP/HIGH PRESSURE MECHANICAL SEAL. Cartridge Design allows replacing seal with out removing the motor.
 - ALL WETTED COMPONENTS OF AISI 304 STAINLESS STEEL for corrosion resistance.
 - TUNGSTEN CARBIDE VS CERAMIC BUSHINGS for long life at high temperatures.
4. PRESSURE REDUCING valves automatically reduce higher inlet pressure to a constant downstream pressure regardless of changing flow rate or inlet pressure. Pilot control settings are readily accessible and are easy to adjust. Return flow is prevented through built in check valves. For some applications where constant discharge pressure is not critical or where suction pressure is relatively constant as with a reservoir, silent check valves may be substituted for pressure reducing valves.
5. PRESSURE GAUGES are located on panel.
6. STEEL MANIFOLDS are painted Aurora Blue for corrosion resistance and to meet various local codes. Flanged connections provide easy installation. All piping is Schedule 40.
7. WELDED GROUTABLE STEEL BASE provides complete support while still allowing the unit to be readily maneuvered for installation.
8. FULL-PORT BALL VALVES provided on each pump suction and discharge branch will allow individual pumps to be serviced without interrupted operation.
9. THERMAL RELIEF VALVE is installed in pump casing to prevent overheating and pump failure. The valve will automatically sense the rise in temperature and discharge some of the hot fluid causing the cooler fluid to enter the casing and the valve will then close.
10. HYDROPNEUMATIC PRESSURE TANK (not illustrated) can be optionally provided to maintain system pressure during periods of low demand. Depending on specific application, the tank can be located adjacent to the system in the equipment room, remotely located, or mounted with the system on the common baseplate.

Pump and System Selection Guide

All Packaged Booster Systems have a desired discharge pressure and a given suction pressure from the city water system, or from a suction tank. Individual pump boost pressure is usually the system boost plus the friction losses within the booster system pipe, fittings, and pressure reducing valves. Individual pump flow is usually two equal sized pumps on a duplex system, and a percentage such as 20% + 40% + 40% = 100% for a triplex system. Determine the system flow and boost as well as individual pump flow and boost.

- 1) Total System Flow in GPM _____
 Determine required flow per pump in GPM P1 _____
 (Total System Flow ÷ No. of Pumps) P2 _____
 P3 _____

- 2) Determine System Manifold Size
- | | |
|----------------|----|
| 0 – 140 GPM | 2" |
| 141 – 300 GPM | 3" |
| 301 – 600 GPM | 4" |
| 601 – 1000 GPM | 6" |

- 3) Determine Pump Head (TDH)
- A: Desired Pressure at System Discharge Manifold _____ PSIG
- B: Minimum Pump Suction Pressure _____ PSIG
 (City Supply or Tank)

Determine PRV Size(s)

PUMP FLOW	0-110 GPM	111-191 GPM	192-280 GPM	281-435 GPM
PRV SIZE	1-1/2"	2"	2-1/2"	3"

- C: Determine Flow Losses based on PRV Size _____ Ft. (See Chart Below)

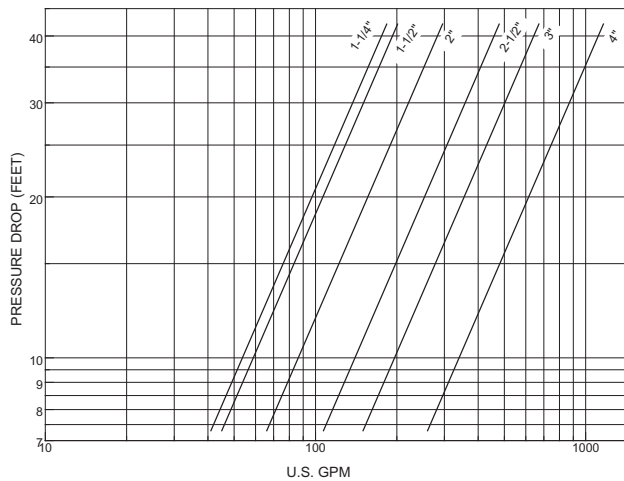

Calculate Required Pump TDH: [A - B] x 2.31 + C
 [(A) _____ PSIG - (B) PSIG] x 2.31 + (C) Ft. = _____ Ft.

Individual Pump Duty Points:

P1 _____ GPM @ _____ Ft. TDH
 P2 _____ GPM @ _____ Ft. TDH
 P3 _____ GPM @ _____ Ft. TDH

- 4) Select required pumps and motors using Aurora H2Optimize or the current Aurora Pump catalog

Range Charts

3450 RPM

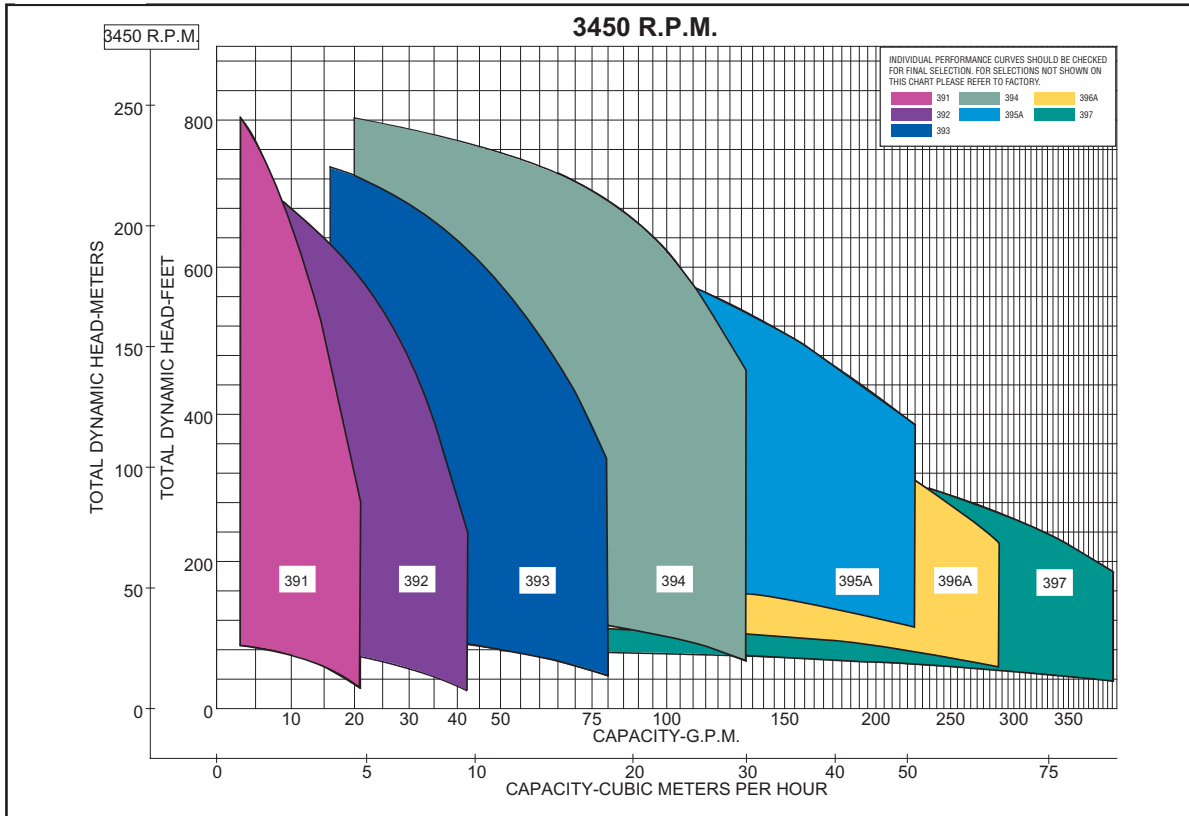

2880 RPM

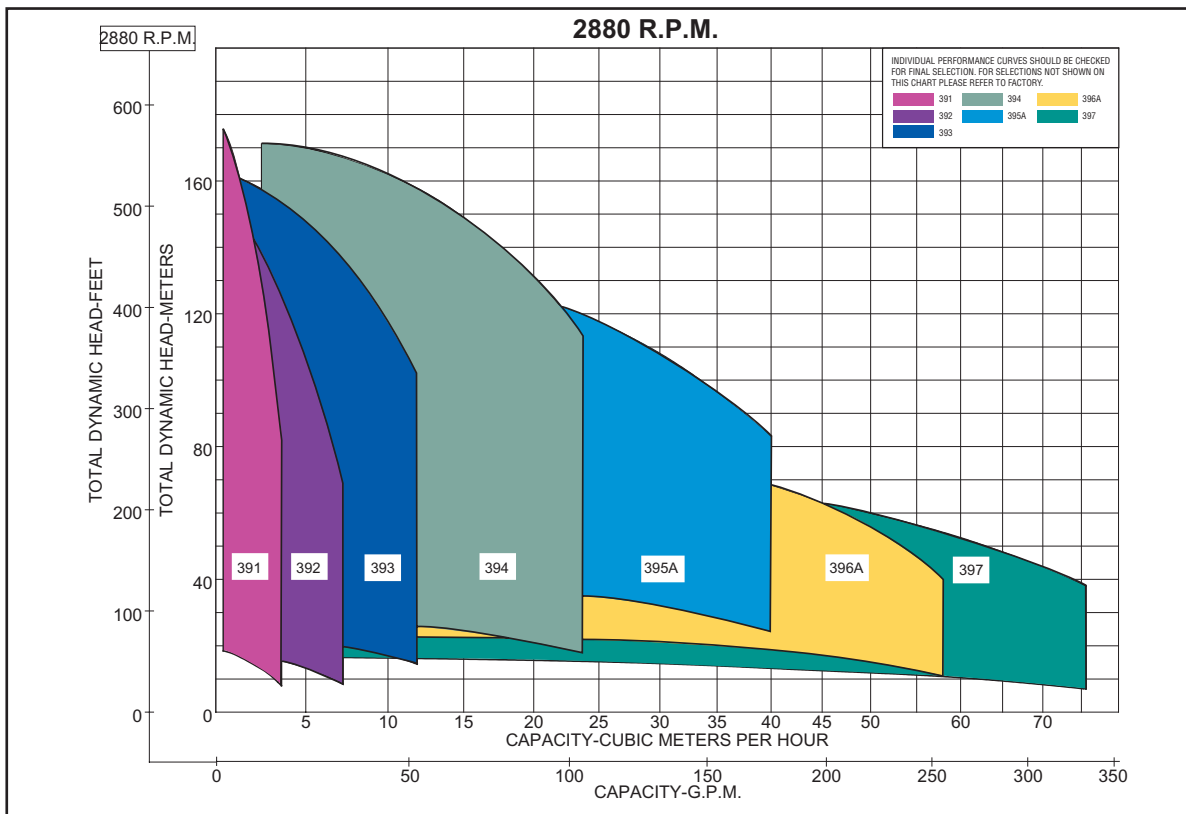

Pump Dimensions

DUPLEX

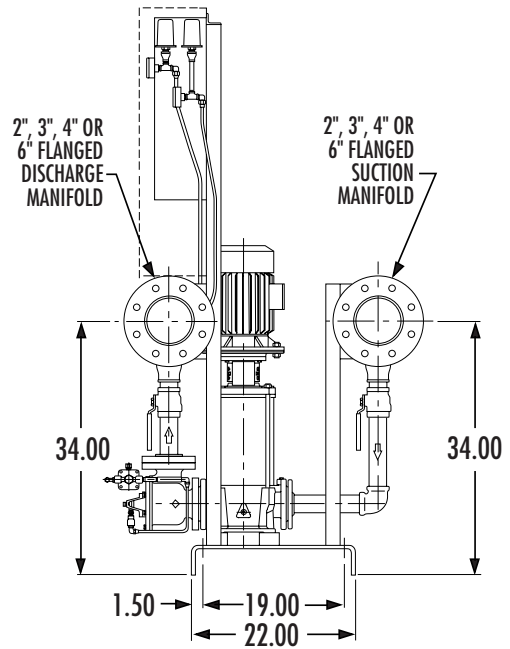
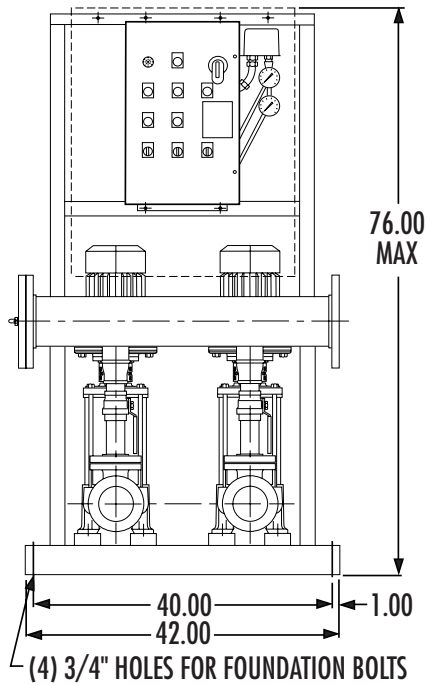

DUPLEX WITH TANK

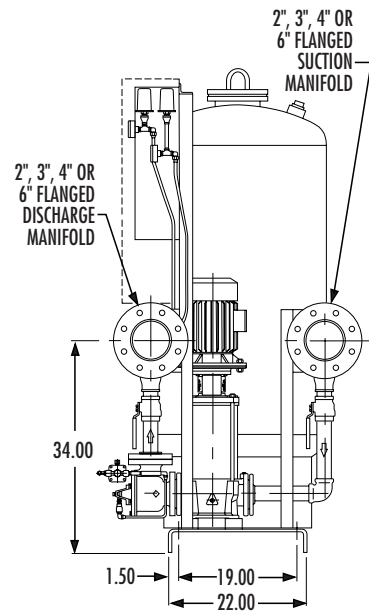
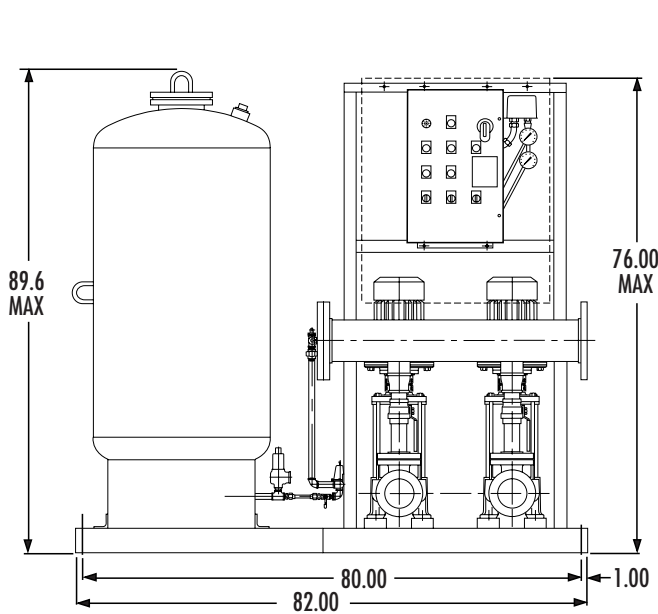

Pump Dimensions

TRIPLEX

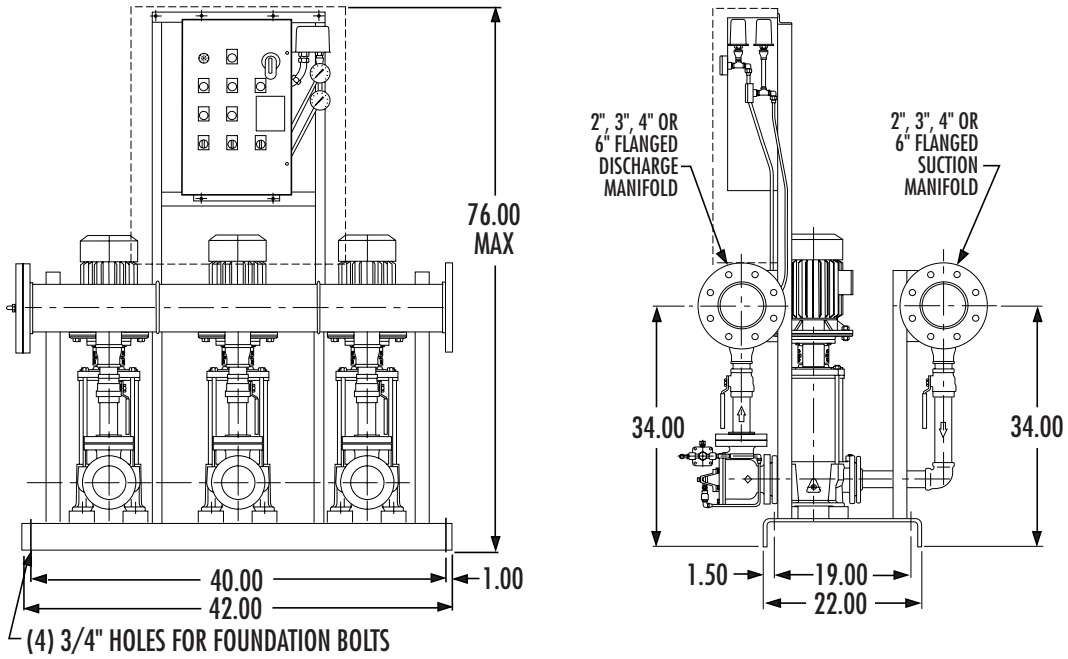

TRIPLEX WITH TANK

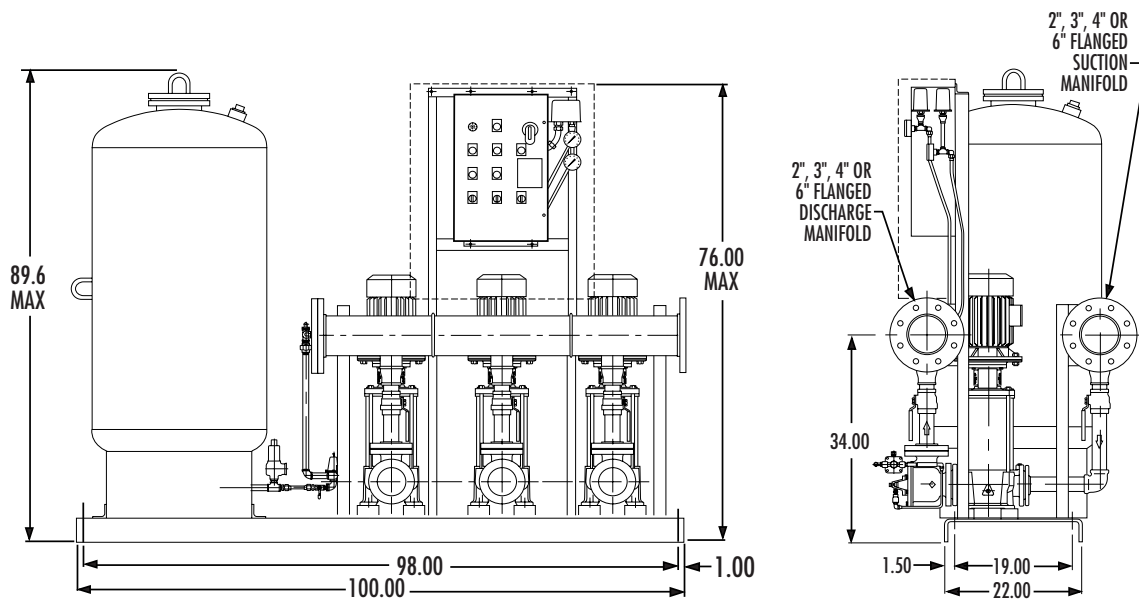

Engineering Specifications

The contractor shall furnish and install an Aurora Variable Flow (Duplex or Triplex) constant Pressure Booster System as manufactured by Aurora Pump. The unit shall have a total system capacity of.....GPM at a discharge head of.....feet when supplied with a working suction head of.....feet. Each pump shall be sized as indicated for a % of the total flow.

Duplex System

PumpP1 =.....GPM.....%System

PumpP2 =.....GPM.....%System

Triplex System

PumpP1 =.....GPM.....%System

PumpP2 =.....GPM.....%System

PumpP3 =.....GPM.....%System

PIPING AND VALVES

Each system shall be skid mounted, completely assembled and wired on a groutable steel base ready for installation. All piping shall be Schedule 40 Steel pipe. Each system shall include suction and discharge ball valves for each pump suction and discharge, combination pressure regulating/non-slam check valves for each pump, flanged connections for easy installation and pipe supports for the upper manifold. Suction and discharge pressure gauges shall be provided. Gauges shall have 3-1/2" faces with large scale numerals

and individual air bleed type valves.

PUMPS

The pumps shall be Aurora vertical multi-stage in line pumps. Each pump shall be constructed with 304 Stainless Steel impellers and diffusers, a high temperature mechanical seal with carbon vs Silicon Carbide, EPDM elastomer through out, Tunsten Carbide against Ceramic pump bushings and a Cast Iron motor bracket. Flanges will be Ductile or Cast Iron in Slip ring (and isolated from liquid).

MOTORS

The motors shall be NEMA C-FACE,HP, 3 phase, 60 Hertz,Volt, ODP, High-Efficiency. Motors shall be selected so that they do not exceed their nameplate HP rating through their entire range of operation.

CONTROL PANEL-PRESSURE SENSING

Each system shall have a mounted and wired UL Listed NEMA I Control Panel with individual magnetic motor starters, ambient compensated overload relays on each phase, individual motor fuseblocks with fuses, main circuit disconnect switch with door interlock, 110 volt control transformer with primary and secondary fuses. The panel shall be suitable for the horsepower and voltage of the motors. The Control Panel will incorporate a programmable logic

controller with pressure-sensing logic and have the following features:

- On and Off delays factory set to system operating characteristics to prevent short cycling of pumps.
- Individual pump run lights and selector switches
- Failure logic and indicating light to activate second pump if lead pump malfunctions.
- Automatic Lead/Lag pump alternation
- Low suction pressure shutdown with alarm light, horn and reset button.

TESTING

The entire system shall be tested at the factory to assure proper sequencing to meet the design flows and pressure; and the system components shall be adjusted at the factory.

SERVICES

The pump manufacturer shall assume unit responsibility and shall provide a factory trained engineer to supervise initial start-up to insure proper operation and to instruct the operating personnel in the operation and maintenance of the system.



NOTE: Aurora Pump reserves the right to make revisions to its products and their specifications, and to this bulletin and related information, without notice.

— Your Authorized Local Distributor —



MARKETING & SALES:

800 AIRPORT ROAD • NORTH AURORA, ILLINOIS U.S.A. • 60542
PHONE: (630) 859-7000 U.S.A./CANADA FAX: (630) 859-7060
WORLDWIDE FAX: (630) 859-1226

WEB: www.aurorapump.com

EMAIL: aurora_info@pentairpump.com

AURORA MFG. PLANT:

800 AIRPORT ROAD • NORTH AURORA, ILLINOIS U.S.A. • 60542

SALES OFFICES IN ALL MAJOR CITIES AND COUNTRIES

Refer to "Pumps" in yellow pages of your phone directory for your local Distributor.

